

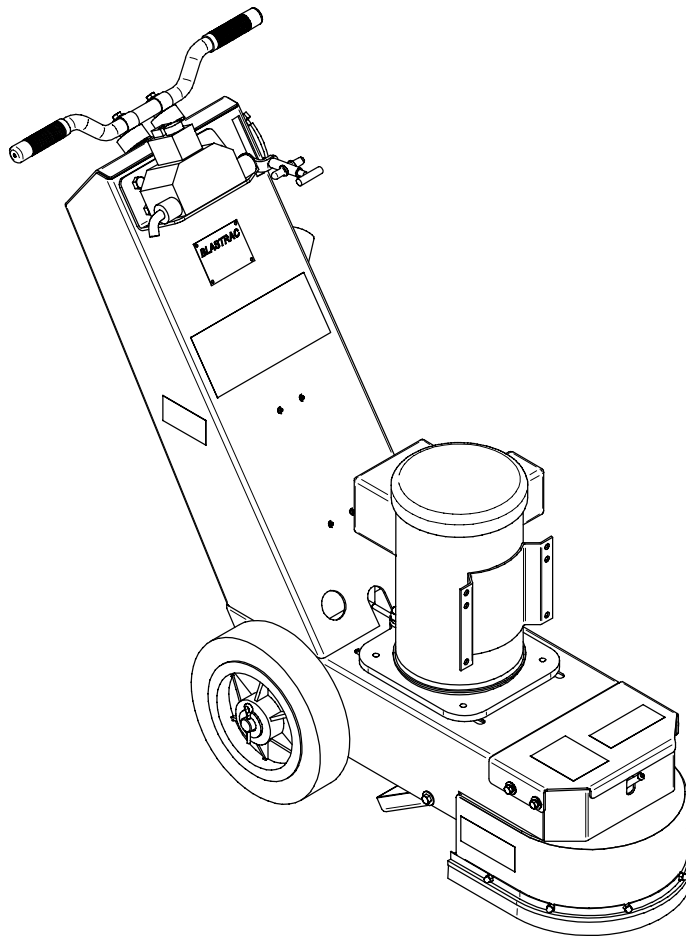

*BG-250-230/60*  
*Electric 230v, 1ph*  
*Concrete Grinder*



**Blastrac**  
6215 N. Aluma Valley Dr.  
Oklahoma City, OK 73121  
1-800-256-3440



---

**Contents Chapter 1**

---

- 1.1 Rating
  
- 1.2 Unit specifications
  
- 1.3 Operating range and correct usage
  
- 1.4 Machine type designation
  
- 1.5 Advice for operators of the machine

---

## 1.1 Rating

---

Unit / Designation: **Blastrac** Grinding machine

Machine type: **BG 250-230/60**

Manufacturer:



**Blastrac**  
6215 N. Aluma Valley Dr.  
Oklahoma City, OK 73121

---

## 1.2 Unit specifications

---

Technical data:

Grinding Machine	BG-250-230/60
Power consumption	5 HP
Tool diameter	10 in (250 mm)
Working width	10 in (250 mm)
Dust hose connection	3 in (75 mm)
Recommended Dust Collector	Blastrac® Turbo-Vac II or Blastrac 1-13DC
Noise Level	78 DBA
Vibration Level	< 2,5 ms <sup>2</sup>

Dimensions:

	<b>BG-250-230/60</b>
Length	49.25 in (1250 mm)
Width	24.50 in (620 mm)
Height	39.38 in (1000 mm)
Weight	271 lbs (123 kg)

---

### 1.3 Operating range and correct usage

---

**The BG-250-230/60 is exclusively designed to grind horizontal surfaces. The machine may not be used for other purposes. The manufacturer will not be liable for damage or injury resulting from such incorrect usage.**



---

### 1.4 Machine type designation

---

Machine Type – BG (Blastrac Grinder)  
Working Width – 250 (mm)  
Power Plant – 230/60 (5 HP, 230v, 60 Hz, 1ph)

---

## 1.5 Advice for operators of the machine

---



When you use the BG-250-230/60 it is **possible** to exceed the maximum allowable sound level of 85 db(A). That sound level will vary **depending on the location**. If the sound level reaches 85 db(A) or more, the operator and the surrounding personnel must wear OSHA approved hearing protection.



Verify that you always rest the machine on the kick stand if not grinding. If you rest the machine on the grinding disc, the flexible coupling will deform, causing unequal wear on the tools and increased vibration level.



---

**Contents Chapter 2**

---

- 2.1 Warnings and symbols
- 2.2 Organizational measures
- 2.3 Personnel selection and qualification
- 2.4 Safety precautions applicable to some operating sequences
- 2.5 Special work instructions
- 2.6 Definition of the **Maintenance Mode**
- 2.7 Possible dangerous aspects of the equipment
- 2.8 Electrical

---

## 2.1 Warnings and symbols

---

The following symbols are used in the Operating Instructions to highlight areas of particular importance:



**Symbol of operational safety.**  
In these Operating Instructions this symbol will be shown next to safety precautions that are to be taken in order to increase safe operation of the machine. Follow these instructions and take special care in these circumstances. In addition to these instructions, your general organizational safety precautions and accident prevention guidelines are also to be followed.



**Details regarding the economical use of the equipment.**



Information, instructions and restrictions with regard to possible risks to personnel and/or to extensive machine damage.



**Warning against dangerous voltages.**



**Indications relating to protective devices in electrical appliances.**



**Indications where consultation with the manufacturer is required.**



**Instructions relating to periodic checks.**

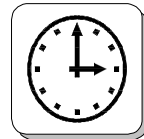

**Reference to important instructions contained in the Operating Instructions.**



## 2.2 Organizational measures

---

The **Operating Instructions** are to be kept **near the machine all times**.



In addition to the Operating Instructions, general and legal regulations regarding accident prevention and environmental protection must be complied with.

Such duties may, for example, relate to the handling of hazardous substances, wearing of personal protective equipment and compliance with traffic regulations.

The Operating Instructions must be **supplemented by instructions** including the duty to **supervise** and **report** relating to **particular working practices**, for example work organization, work procedures and personnel allocation.

Personnel entrusted with working with the machine must have read the entire **Operating Instructions** before starting work. To read these instructions during work is too late. This particularly applies to incidental activities such as setting up the equipment, carrying out maintenance work or training staff to work with the machine. Read and understand the Honda Engine Manual before using this equipment.

From time to time the working practices of the staff are to be checked regarding awareness of **safety concerns and hazards**.

Personnel must tie back long hair and not wear loose clothing or jewellery including rings.

Use **personnel protection equipment** if necessary or required by regulations. Take notice of **all** safety and hazard notices on the machine.



All **safety and hazard notices** at or on the machine must be kept complete and **legible**.

If **safety-critical changes** occur to the machine or its working method, the machine must be **shut down immediately**. The cause of the fault must be established immediately and corrected prior to further operation of the machine.

**Changes**, add-ons or conversions to the machine which might impair safety **must not** be undertaken **without the manufacturer's written permission**.



This applies in particular to the fitting and adjustment of safety devices as well as to welding on load-bearing parts.

Spare parts must comply with the technical requirements specified by the manufacturer. This is always guaranteed if original spare parts are used.

**Intervals** for recurring **checks and inspections** specified in these Operating Instructions must be complied with.

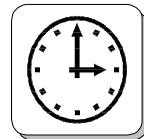

To perform maintenance work correctly it is imperative to be equipped with the proper tools for the task.

The **location** and the operation of **fire extinguishers** must be made known at each work site.



Take note of the facilities for reporting and fighting fires.

---

### **2.3 Personnel selection and qualification**

---

Fundamental duties:

Work on the machine may only be undertaken by **authorized personnel**.

Only trained personnel may be deployed. **Note the statutory minimum age**. Specify clearly the responsibilities of personnel for operation, setting up, servicing and maintenance work.

**Make sure** that only **authorized** personnel operate or work on the machine.

Personnel being trained on the equipment may only be deployed on the machine **under constant supervision of an experienced person.**

Work on **electrical** equipment or operating materials may only be undertaken by a **skilled electrician** or by **trained** persons under the **guidance** and **supervision** of a **skilled electrician** as well as in accordance with the **electrical engineering regulations.**



---

#### 2.4 Safety precautions applicable to some operating sequences

---

Ban any method of working that **impairs safety.**

Some measures have to be taken in order to operate the machine in safe and operative conditions.

Only operate the machine when all **safety devices** and related safety equipment, e.g. detachable **safety devices**, emergency stops and suction devices are present and **working correctly.**



Check the machine visually for any **damage** and **defects** at least once a day.

In the event of **operational malfunctions**, the machine must be **shut down immediately** and secured.

Secure the **work area** around the machine in **public areas** providing a **safety distance** of at least 6ft from the machine.



Faults must be repaired prior to further operation of the machine.

Before switching on the machine make sure that no-one can be endangered when the machine starts up.

Do not switch off or remove the exhaust and ventilation devices when the machine is running.

All persons in the proximity of the machine, when it is working, must wear ear protection and safety shoes. The operator is obliged to wear close-fitting protective clothing.



---

## 2.5 Special work instructions

---

### **Mechanical servicing work:**

Put the machine in the **Maintenance Mode** as described in chapter 2.6 for any servicing work on the machine.



Follow any special **safety instructions** in the various chapters on servicing the machine.

**See chapter 7.1 - 7.9.**

**Adjustment, servicing and inspection work and time limits** specified in these Operating Instructions, as well as any information on the replacement of parts and equipment must be **undertaken and/or complied with**.

These activities may only be undertaken by **qualified personnel**.

The **operator has to be familiar with the maintenance work** before starting the process.

If the equipment is switched off in order to do maintenance, repair or adjustment it has to be secured against unintended restart. **Machine must be in Maintenance Mode as described in Chapter 2.6 before servicing.**

See **Chapter 2.6 Maintenance Mode for specific details.**

**Always dispose** of the contents of the **dust bin** of a possible connected dust collector used before **loading** it on van or truck. Observe the **waste disposal regulations**; if uncertain situation ask your supervisor.

Do not use any **aggressive** cleaning materials.

Use lint-free **cleaning cloths**.

Always tighten any screw connections that are undone during servicing and maintenance work.

If **safety devices** need to be taken off or **dismantled** during service and repair, these **safety devices** must be **reinstalled** and inspected immediately after completion of the servicing and repair work.

**Make sure that process materials and replaced parts are disposed of safely and in an environmentally-friendly manner.**

Work on **electrical** equipment or operating materials may only be undertaken by a **skilled electrician** or by **trained** persons under the **guidance** and **supervision** of a **skilled electrician** as well as in accordance with the **electrical engineering regulations**.



Make sure that electrical components used for replacement purposes comply with the original parts and are correctly adjusted if necessary.

## **2.6 Definition of the Maintenance Mode**

---

### **Definition:**

The machine is in a safe condition when it cannot generate any hazard.

Putting the equipment in the Maintenance Mode means:

- Lift up the machine (see Chapter 5)**
- Switch off the machine.**
- Switch off the dust collector.**
- Wait for standstill of all drives.**
- Secure against unintended restart**

---

## 2.7 Possible dangerous aspects of the equipment

---

Any machine, if it is **not used according the regulations**, may be **hazardous** for operating, setting-up and service personnel. The **operating authority** is responsible for **compliance with the safety regulations** during operation and maintenance of **safety devices** supplied with the machine as well as the provision of appropriate additional safety devices.



---

## 2.8 Electrical

---

Work on **electrical** equipment or operating materials may only be undertaken by a **skilled electrician** or by **trained** persons under the **guidance** and **supervision** of a **skilled electrician** as well as in accordance with the **electrical engineering regulations**.







**Operating Instructions**

**BG-250-230/60**

**General**

**October 2005**

---

---

**Contents Chapter 3**

---

- 3.1 Range of application
- 3.2 Scope of supply
- 3.3 Description of the machine
- 3.4 Operating elements
- 3.5 The tools
- 3.6 Care and maintenance

---

### **3.1 Range of application**

---

- Typical ranges of application for the BG-250 are for example:
  - To remove undulating concrete and asphalt surfaces
  - To prepare the surface for coatings
  - To remove coating defects
  - To remove residual mineral adhesives
  - Smoothing of concrete

---

### **3.2 Scope of supply**

---

Scope of supply of the machine:

- Grinding Machine (BG 250-230/60)
- Dust collector: Turbo-Vac II or 1-13DC (Optional)
- Dust hose (Optional)
- Blastrac Operating Instructions

The dust collector you have chosen for your machine ensures nearly dust free operation and also improves machine and tool life. Blastrac uses specially designed dust collection systems with high separation efficiency, thus extending the life of the machine components.

---

**3.3 Description of the machine**

---

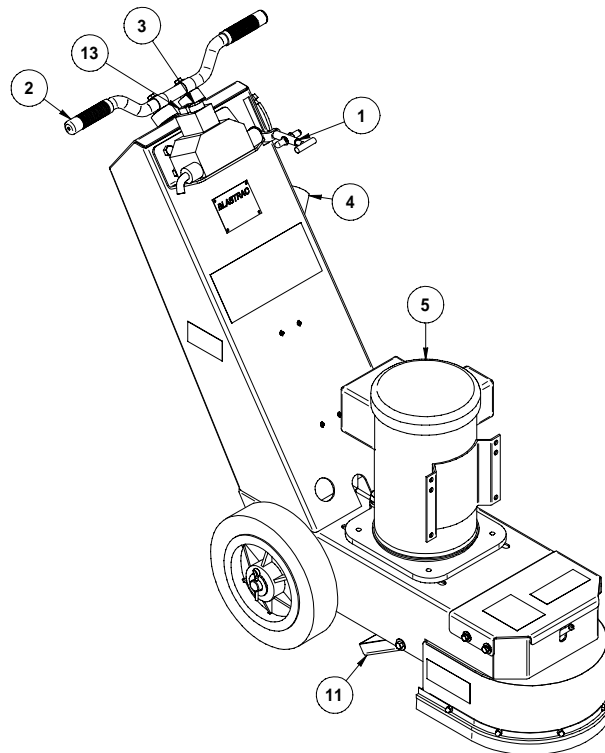
**Fig. 3.1**

1	Hand lever for jack stand	6	Grease Nipple (see Fig 3.4)	11	Jack stand
2	Handgrip	7	Bearing Unit (see Fig 3.4)	12	Caster
3	Emergency stop	8	Flexible coupling (see Fig 3.4)	13	"On" Button
4	Suction connection port	9	Diamond disc (see Fig 3.4)		
5	Driving motor	10	Brush seal (see Fig 3.4)		

The Blastrac grinding machine BG-250-230/60 can produce a pattern of 10 inches (250 mm) and distinguishes itself by its high economic efficiency and easy handling. The machine levels uneven and undulating floors, therefore is also suitable for optimisation of surfaces before blasting. Levelling the surface will require less coating to be applied, thus reducing coating costs. The BG-250-230/60 has a grinding speed of 3200 rpm. A flexible coupling allows the disc to float over varied terrain, therefore keeping diamond contact to the surface at a maximum.

**3.4 Operating elements****Handgrip and Jack Stand Operating lever**

Fig. 3.2

Before Switching on the BG-250-230/60, the front part of the grinding machine must be lifted by pushing down on the handgrip (2) and pulling back on the jack stand operating lever (1). When the machine has started, retract the jack stand and slowly lower the disc to the work surface. Never slam the disc to the work surface; this may cause machine damage and injury to personnel.

---

**Starting/Stopping**

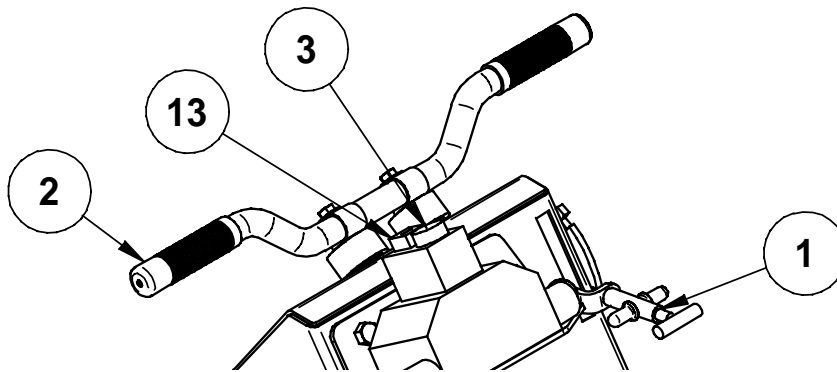
---

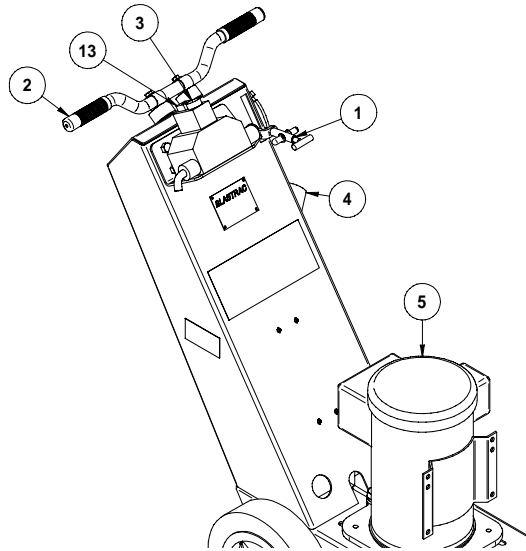

Fig. 3.3

3 Emergency stop switch

13 "On" Button

---

**Starting**

---

See "Handgrip and Jack Stand Operating Lever" and make sure the diamond disc is off the ground and the machine is secure before starting. Verify all electrical connections are made and surrounding area is clear. Grab handle with one hand and depress "On" button with free hand.

---

**Emergency Stop switch**

---

Pressing this switch immediately interrupts the power supply of the machine. This red button can also be used as an OFF switch.

## 3.5 The Tools

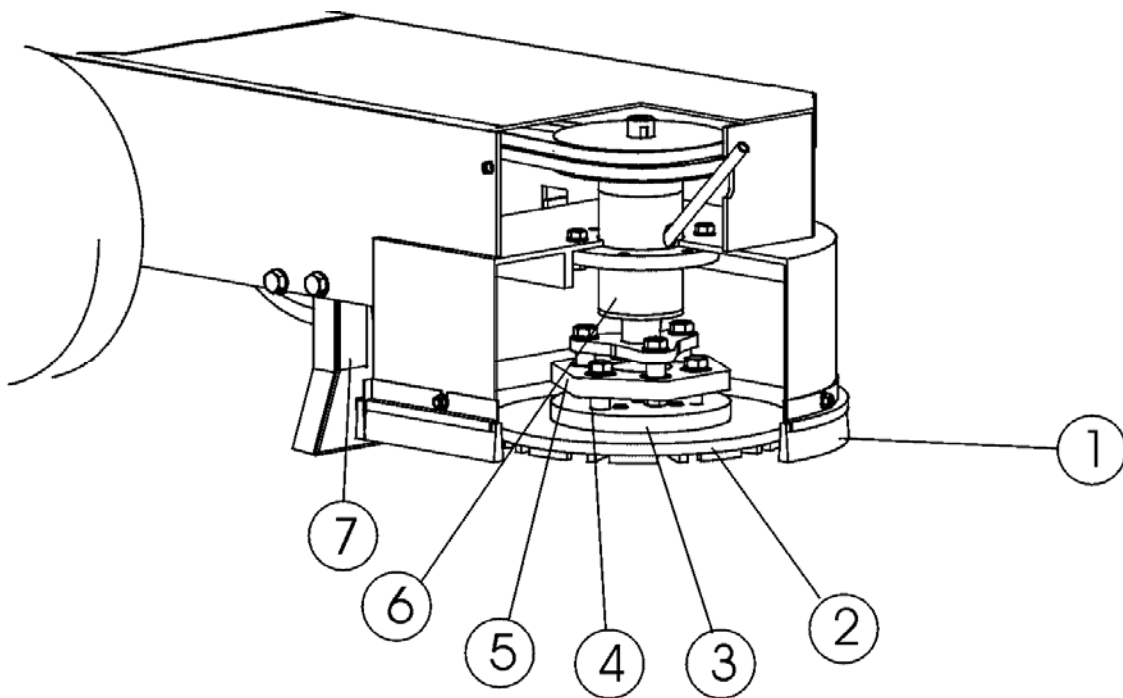

Fig. 3.4

- |   |                       |   |                   |
|---|-----------------------|---|-------------------|
| 1 | Brush seal            | 5 | Flexible-Coupling |
| 2 | Diamond grinding disc | 6 | Bearing-Unit      |
| 3 | Adapter               | 7 | Jack stand        |
| 4 | Spacer                |   |                   |

---

**3.6 Care and maintenance**

---

Special attention and regular maintenance of the machine are imperative for decreasing safety risks and increasing machine efficiency.

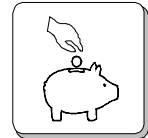

Pay attention to unusual noises or strong vibrations. Check for the cause of any change in operation. Contact Blastrac with any questions regarding the operation or maintenance of the machine. Never operate the machine if you are unsure.

Be sure the BG-250-230/60 is clean and free of any debris before operating. Turn off the machine and check the cleanliness periodically and clean if necessary.

The bearing unit should be lubricated at least every three months. Lubrication intervals will be dependant on the machine usage.

Before using the machine you should always check to make sure all bolted connections are tight and there are no loose connections on the machine.



---

**Contents Chapter 4**

---

- 4.1 Unit specifications
- 4.2 Manual mode of moving the machine
- 4.3 Transport with cranes or lifts
- 4.4 Transport of the machine with vehicle



---

#### 4.1 Unit specifications

---

Model	<b>BG-250-230/60</b>
Dimensions L x W x H	49.25" x 24.50" x 39.38" (1250 x 620 x 1000)
Weight	270 lbs (105 kg)

#### Optional: Dust Collector

Model	<b>Turbo Vac II</b>	<b>1-13 DC</b>
Dimensions (mm) L x W x H	20.00" x 18.00" x 51.00" (508 x 457 x 1295)	31" x 19" x 29" (788 x 483 x 737)
Weight - empty	68lbs (31 kg)	120 lbs (55 kg)

---

#### 4.2 Manual mode of moving the machine

---

In order to move the machine, press down the handgrips to raise the blade off the surface. Now you can move the machine to the new position.

The machine will be transported after being separated into:

- Grinding machine
- Dust collector unit (Turbo Vac II or 1-13 DC)
- General accessories

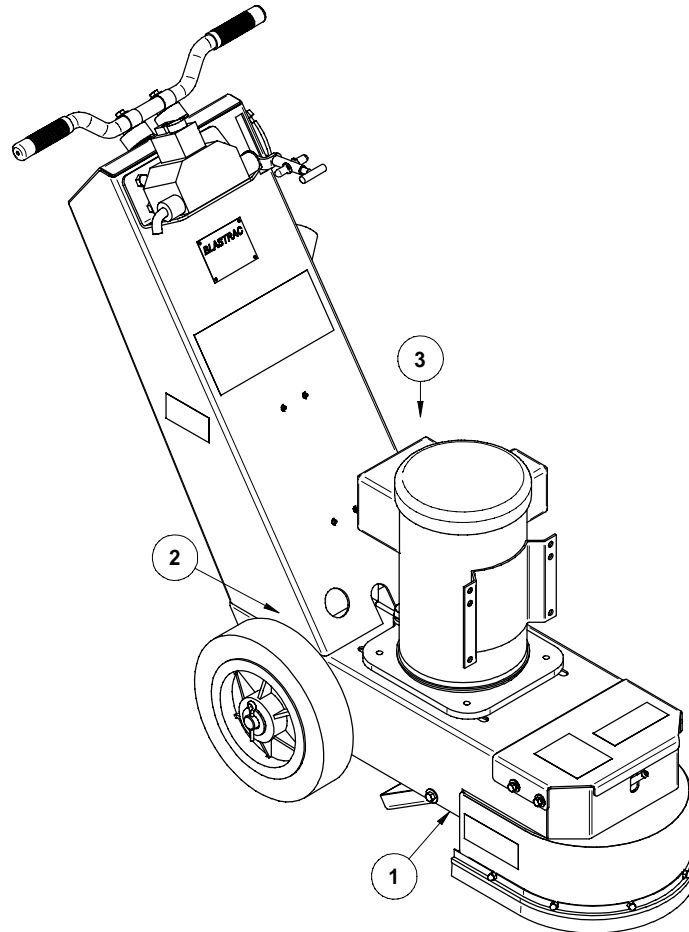

Fig. 4.1

---

### 4.3 Transport with cranes or lifts

---

If you have to transport the machine with **hoists** like crane or lifts, pay attention to the maximum load of these devices. Use only approved sling devices rated for the specified load. **Notice the machine weight** from **chapter 4.1 "Unit specifications."** Never fasten a sling or lifting device to, or around, the handle of the machine. The handle will break causing damage and injury.

Place three slings at the points shown above: (1) sling under main chassis just in front of jack stand. (2) Sling under wheel axle between wheel and chassis (3) sling under wheel axle between wheel and chassis on other side of machine

Lift the load slowly and make sure it is stable before transporting.

**4.4 Transport of the machine with vehicle**

---



Always put kick stand down, keeping the blade off the surface when transporting. When the jack stand is down secure the machine with straps and block wheels to make sure the machine will not move during transport. Never transport the machine with gasoline in the tank. Enclosed trailers or vehicles may be dangerous due to the gasoline present in the machine. Be aware of fumes that may exist in transport and storage. These fumes may present a fire hazard if exposed to extreme heat, spark or open flame.





**Operating Instructions**

**BG-250-230/60**

**Initial Operation**

---

**October 2005**

---

**Contents Chapter 5**

---

5.1 Preparation for initial operation

5.2 Initial operation

## 5.1 Preparation for initial operation



Before start-up the operating personnel must be familiar with the safety regulations given in this manual.

- Put the grinding machine and the dust collector on the surface to be treated.
- In the case you have not yet installed any diamond grinding disc, you have to install it now. Please **read chapter 7 "Maintenance"** of this manual.
- Check the dust hose for damages
- Connect the grinding machine and the dust collector with the dust hose. Use hose clamps at the connections.
- Make sure the dust bin of the dust collector is empty.



Any machine, if not used according to regulations, may be hazardous for operating, setting up and servicing. The operator/owner is responsible for compliance with the safety regulations during operation and maintenance of safety devices supplied with the machine as well as the provision of appropriate additional safety devices.

---

## 5.2 Initial operation

---

---

### Handgrip and Operating lever

---

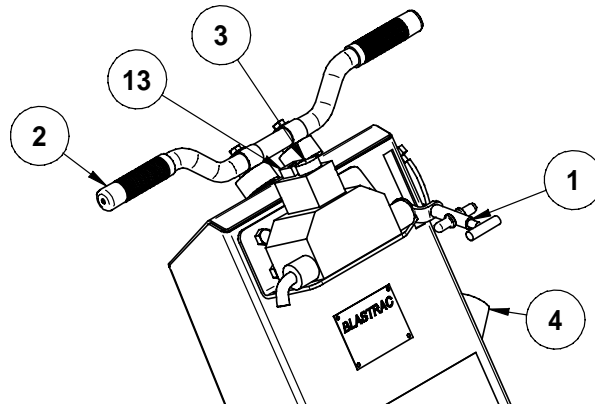

Fig. 5.1

Before Switching on the BG-250-230/60, the front part of the grinding machine must be lifted by pushing down on the handgrip (2) and pulling back on the operating lever (1). Pulling back on the operating lever (1) will lower the kick stand and take the weight off the grinding disc. Be sure machine is stable prior to starting the motor. When the machine has started, retract the kick stand and slowly lower the disc to the work surface. Never slam the disc to the work surface; this may cause machine damage and injury to personnel.



**Kick stand in retracted position**

Fig. 5.2

---

## Starting/Stopping

---

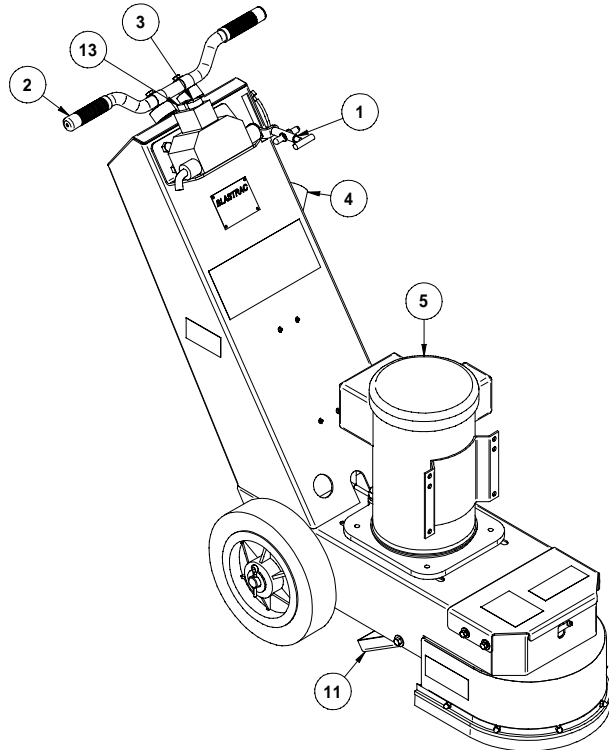

Fig. 5.3

- 3 Emergency stop switch                      13 "On" Button

---

## Starting

---

See "Handgrip and Operating Lever" and make sure the diamond disc is off the ground and the machine is secure before starting. Verify all electrical connections are made and surrounding area is clear. Grab handle with one hand and depress "On" button with free hand.

---

**Emergency Stop switch**

---

Pressing this switch immediately interrupts the power supply to all units of the machine. This red button is also used as OFF switch.

---

**Stopping**

---

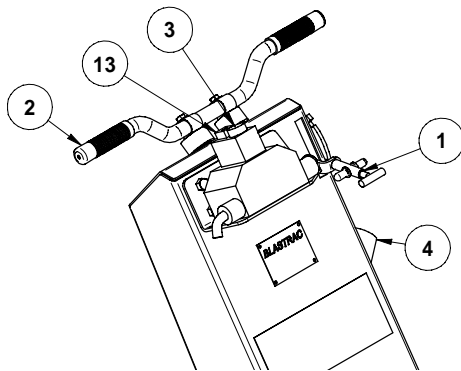

The grinding machine must be lifted by pushing down on the handgrip (2) and pulling back on the operating lever (1). Pulling back on the operating lever (1) will lower the kick stand and take the weight off the grinding disc. Push E-stop (3).

Figure 5.4







---

**Contents Chapter 6**

---

- 6.1 Operation
- 6.2 Switching-off the machine
- 6.3 Emergency Shutdown
- 6.4 Safety shutdown
- 6.5 Restarting after a fault
- 6.6 Procedures after lengthy down time

---

## 6.1 Operation

---



The **Operating Instructions** are to be kept **near the location where the machine** is located and must be **within reach at all times**. **Note the statutory minimum age!** Specify clearly the responsibilities of personnel for operation, setting up, servicing and maintenance work. **Make sure** that only **authorised** personnel operate or work on the machine.



A regular inspection is necessary to prevent downtimes of your grinding machine. **See chapter 7 "Maintenance"**.

Pay attention to following aspects during operation of the **Blastrac Grinding machine BG-250-230/60**

- Before beginning daily grinding work, be sure all fasteners are tight and secure. Pay special attention to those that connect drive components.
- Before switching on, make sure that all guards are in place. Be sure the dust collector is correctly connected and switched on.
- Blastrac specially recommends operating the machine with only one dust collector that has enough suction capacity and high filtration efficiency.
- Handle all plugs, cables, hoses and operating elements carefully.
- Before grinding, clean the surface to be treated with a broom. Be sure there are no objects on or in the floor that may cause damage to the machine. Be aware of hidden objects that may be below the surface layer of the concrete.



Always use the appropriate personnel protection when handling and disposing of concrete dust. Dispose according to local, state and federal regulations.

The normal start up of the Blastrac BG-250-230/60 in the daily operation does not differ from the described process in chapter 5.2 "Initial operation".

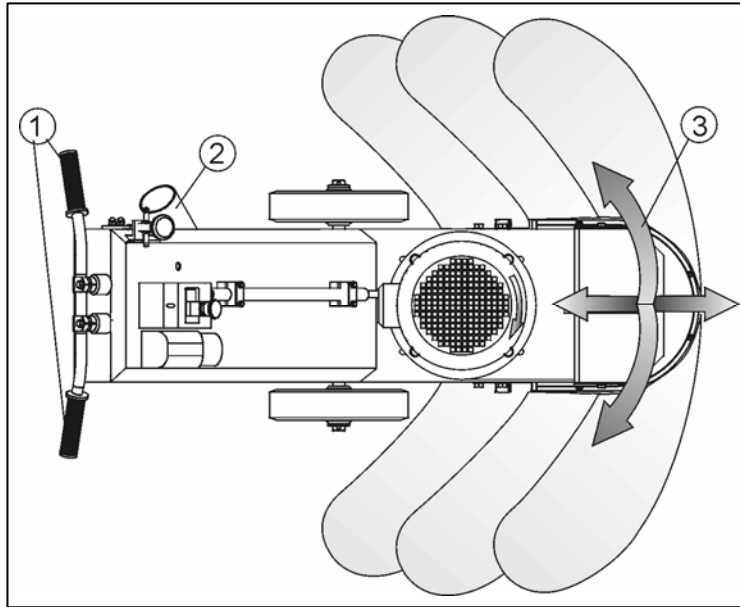

Fig. 6.1 (Electric BG 250 shown)

After connecting the suction tube to the air intake (2) of the machine, you can treat the surface as described in the following.

If you have doubts about how to start up the machine, read sections chapter 5.1 and 5.2 of these operating instructions. Never start the machine if you are not completely confident on how to operate the machine.



You should grind in fan-shaped movements. Sweep the machine at the handgrips (1) and push forward during the sweeping movements or pull the machine in reverse with the same sweeping motion.

The working direction should always be away from the dust collector, to limit possible damage to the dust hose.

Make sure that no vehicles, such as forklift trucks and other equipment run over the electric cable and the dust hose.

**Diamond-Grinding discs**

Following diamond-grinding discs are available for the Blastrac grinding machine BG250.

<b>Tool</b>	<b>Application</b>	<b>Part No.</b>
10 Segment	Concrete levelling/ heavy removal	CG-1010DB
20 Segment	General surface grinding	CG-1020DB
20 Segment Turbo	Concrete smoothing	CG-1020DBT



These diamond grinding discs are specially designed to be use on the concrete surfaces. For questions about your application, please contact your local Blastrac representative. Some blades are available in a variety of segment hardnesses. Segment hardness may be matched to specific jobs resulting in successful applications and improved diamond life.

**6.2 Switching off the machine**

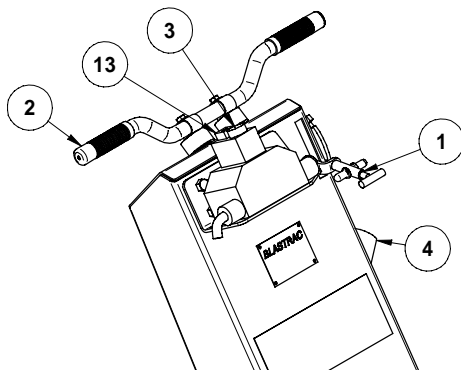

The grinding machine must be lifted by pushing down on the handgrip (2) and pulling back on the operating lever (1). Pulling back on the operating lever (1) will lower the support and take the weight off the grinding disc. Push E-stop (3).

Figure 6.2

Always store the machine on the kick stand when the machine is not being used. If you rest the machine on the grinding disc, the flexible coupling could permanently deform. A deformed flexible coupling may gouge the concrete and will result in uneven diamond wear and excessive vibration. See Chapter 3 for parts identification.

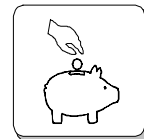

---

### 6.3 Emergency shutdown

---



In case of emergency or abnormal operation, such as vibrations or unusual noises, immediately shut down the machine by hitting the red E-Stop Button (3).

---

### 6.4 Safety shutdown

---



The machine has to be into its “**Maintenance Mode**” before starting repair work. See Chapter 2.6.



Before carrying out inspection or maintenance work make sure that all turning machine parts are stopped. Observe the "Maintenance Mode" condition, chapter 2.6.

Read and understand the entire Blastrac Operating Instructions before operating or servicing this machine. Do not depend on individual chapters for all safety and operating procedures.

---

### 6.5 Restarting after a fault

---

Be sure you fully understand what caused the equipment problem before restarting. If repairs or adjustments have been made to the machine, check the machine thoroughly to make sure all devices are working correctly.

Always verify that the E-Stop is working correctly prior working with the machine.



---

## 6.6 Procedures after lengthy down time

---

### 1 Steps before storage

If the **Blastrac** grinding machine will be stored for a long period or time, follow the below steps:

- Rest the machine onto the kick stand so that the brush seals and the flexible coupling are not touching the floor.
- Clean the machine and cover it with a tarp.

### 2 After storage

- Be sure all fasteners are tight and secure.
- Check to make sure the flexible coupling is not deformed.
- Check electrical cable for cuts and exposed wires. Replace if damaged.
- Verify that the emergency stop switch is working correctly.

Follow steps in Chapter 5 "Initial operation".

---

**Contents Chapter 7**

---

- 7.1 Recommendations
- 7.2 Maintenance and inspection list
- 7.3 Repairing
- 7.4 Grinding disc replacement / assembly
- 7.5 Bearing-Unit
- 7.6 Flexible coupling
- 7.7 The V-Belt drive
- 7.8 The driving motor
- 7.9 Additional maintenance
- 7.10 Spare parts
- 7.11 Influences on the grinding pattern



---

## 7.1 Recommendations

---



**Prior to any repair work on the machine and its drives, secure the machine against unintentional switching-on. Put the machine into its “Maintenance Mode.” Chapter 2.6**

Failures due to inadequate or incorrect maintenance may generate very **high repair costs** and long down periods of the machine. **Regular** maintenance is important to reduce costs and increase productivity.

Operational safety and service life of the machine depend on proper maintenance.

See the Maintenance and Inspection list for recommendations on preventative actions.

The time indications are based on uninterrupted operation. When the indicated number of working hours is not achieved during the corresponding period, the period can be extended. However a full overhaul must be carried out at least once a year.

Due to different working conditions, wear check, inspection and maintenance schedules should be adjusted as needed. Prepare a suitable inspection schedule based on your own working conditions and experience.

Our specialists will be happy to assist you with more advice.



**Follow additional operating and maintenance of OEM if included during your service and maintenance work.**

**Pay attention to special notice given by instructions for electric-motors or combustion engines.**

**7.2 Maintenance and inspection list**

<b>Operating hours/ time period</b>	<b>Inspection points, maintenance instructions</b>
12 hrs after repairing	<ul style="list-style-type: none"> <li>• Check all accessible screw connections for tightness.</li> </ul>
Daily and prior to starting work	<ul style="list-style-type: none"> <li>• Check all safety devices working correctly.</li> <li>• Check the hose to the dust collector filter for damage.</li> <li>• Check the hose inside of the BG-250-230/60 for damage.</li> <li>• Clear any foreign matter from the coupling of the grinding disc.</li> <li>• Make sure that the dust bin of the dust collector is emptied</li> <li>• Check the grinding disc and the coupling for wear.</li> <li>• Verify that the screws in the diamond disc are tight and secure.</li> <li>• Check the tension of the V-belt, tension again if necessary.</li> <li>• Check the brush seal</li> </ul>
Quarterly (Monthly)	<ul style="list-style-type: none"> <li>• Lubricate the bearing-unit and the castor.</li> <li>• Replace the flexible coupling</li> </ul>
Annually	<ul style="list-style-type: none"> <li>• Full overhaul and cleaning of the complete machine.</li> </ul>

---

### 7.3 Repairing

---



As already mentioned in Chapter 5 “Initial operation” we recommend executing the first repair work on the machine under the supervision of **Blastrac** personnel.



You should stock all spare or wear parts that cannot be supplied quickly. As a rule, downtime is more expensive than the cost for the corresponding spare part.

Screws that have been removed must be replaced with those of the same quality (strength, material) and design.



Prior to any repair work on the machine and its drives, secure the machine against unintentional starting. See chapter 2.6.

## 7.4 Grinding disc Replacement / Assembly



Prior to any repair work on the machine and its drives, secure the machine against unintentional starting. Put the machine into its “Maintenance Mode”. Chapter 2.6

### Disassembly:

- 1 Tilt the machine to the back with the help of the handgrips (1) and lay it down on the chassis.
- 2 Now secure the machine against tilt back with a block (2), about 17.75” (45 cm) long. Shake machine to make sure it will not move.
- 3 Unscrew the four countersunk head screws (7) in the grinding disc.
- 4 Remove the grinding disc.

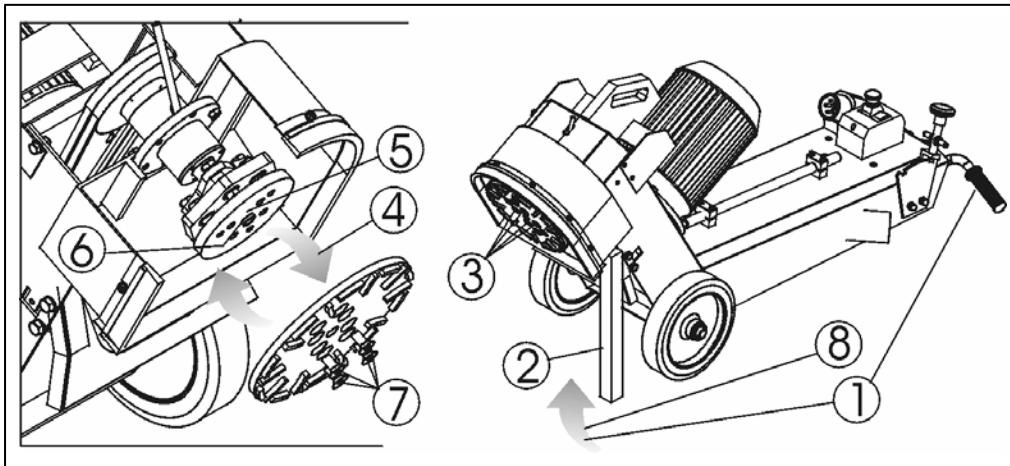

Fig. 7.1 (electric unit shown)

### Assembly:

- 5 Clean the grinding disc adapter thoroughly.
- 6 Adjust the grinding disc in the center.
- 7 Set in and tighten the disc screws (7).
- 8 Remove the block (2) and tilt the machine forwards.

When replacing the grinding disc (4), also check the condition of the coupling and the grinding disc adapter (5). Always replace the worn screws (7).



## 7.5 Bearing Unit-Coupling

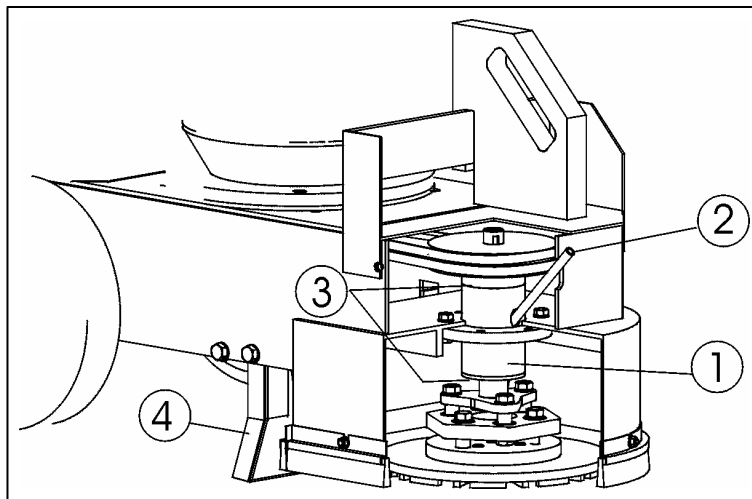

Fig. 7.2 (electric unit shown)

The bearing-unit (1) is a very important component of the machine; you should pay special attention while maintaining and repairing. In the case of a normal use, the bearing must be lubricated every 3 months. If you intensify the use, the bearing must be lubricated at least once a month. In order to lubricate it, give between 3 and 4 strokes grease with a lever type hand gun over the lubricating nipple (2) in the bearing. After lubricating, put the machine on the kick stand (4) let the machine run approximately 5 min. to squeeze out the excess of grease from the housing (1) at the points shown (3). Finally wipe the excess of grease with a cleaning cloth (machine in Maintenance Mode).

Blastrac recommends using grease that is appropriate for a temperature range between 77-270° F (25-130 ° C).

Most lithium based greases will be appropriate. Consult the label for temperature range.

If grease continues coming out during the operation of the machine, the bearing unit must be overhauled or replaced.



Do not use low-grade grease. Low grade grease will overheat the bearing unit causing hot grease to escape and damage to the bearing unit.

## 7.6 Flexible Coupling

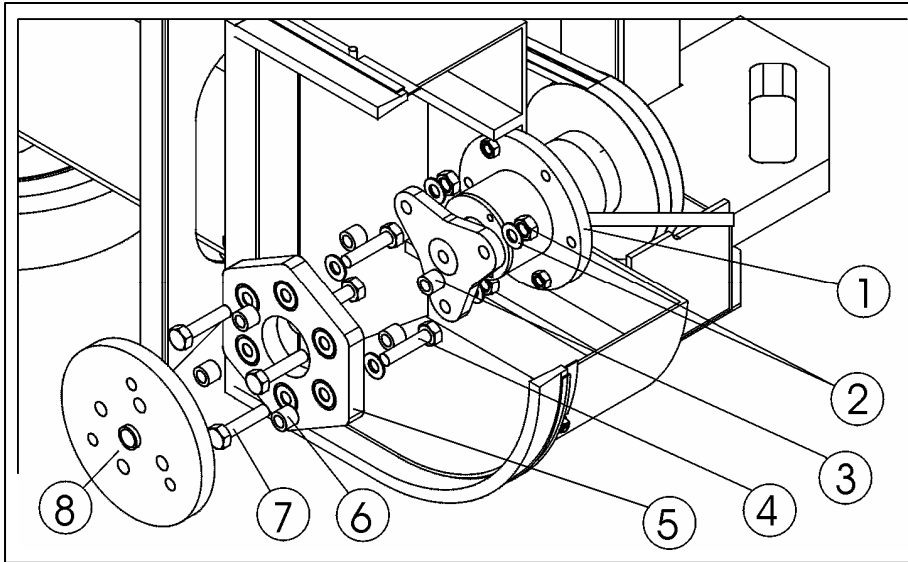

Fig. 7.3 (electric unit shown)

The flexible coupling (5) is a very important component. Depending on the application, the coupling is subject to high thermal and dynamic loads; therefore the service life of the coupling depends on the surface to be treated. That means that the surface structure, the hardness and also the duration of the grinding process have a great influence on the life of the coupling.

When replacing the diamond disc, check the condition of the coupling. If the coupling is cracked or is sitting on an angle with no load on the disc, it should be replaced.



Immediately shut down the machine if unusual vibrations or noises are experienced. Typically the cause of the unusual operation is a defective coupling or debris trapped in the coupling.

### Disassembly:

- 1 Unscrew the upper hexagonal head screws (4) and remove the adapter for grinding disc (8). Check the conditions of the screws and of the spacer tubes (6).
- 2 Unscrew the hexagonal head screws (7) and the nuts fitted at the bearing-unit (2). Check the condition of the screws (4) and of the spacer tubes (6).  
**Always replace all worn or damaged parts.**

## 7.7 V-Belt Drive



**Prior to any repair work on the machine and its drives, secure the machine against unintentional starting. Put the machine to its “Maintenance Mode.” Chapter 2.5**

The V-belt drive is designed specifically for this machine. To force a higher output through an excessive high tension of the V-belt will break the belt, damage the bearing unit. Low belt tension will cause slippage and will result in very high V-belt temperatures. This will cause premature V-Belt wear. Temperatures over 160° F (70° C) for a long period will decrease the working life and the efficiency of the V-belt. The grooves of the V-belt pulleys must be free of rust and dirt and must not show any damage. The use of belt wax or similar substances in order to increase the friction coefficient is not necessary and will damage the V-belt. Collection of dirt due to oil, grease or chemicals must be avoided.

In order to get perfect power transmission the V-belt drive has to be checked regularly.

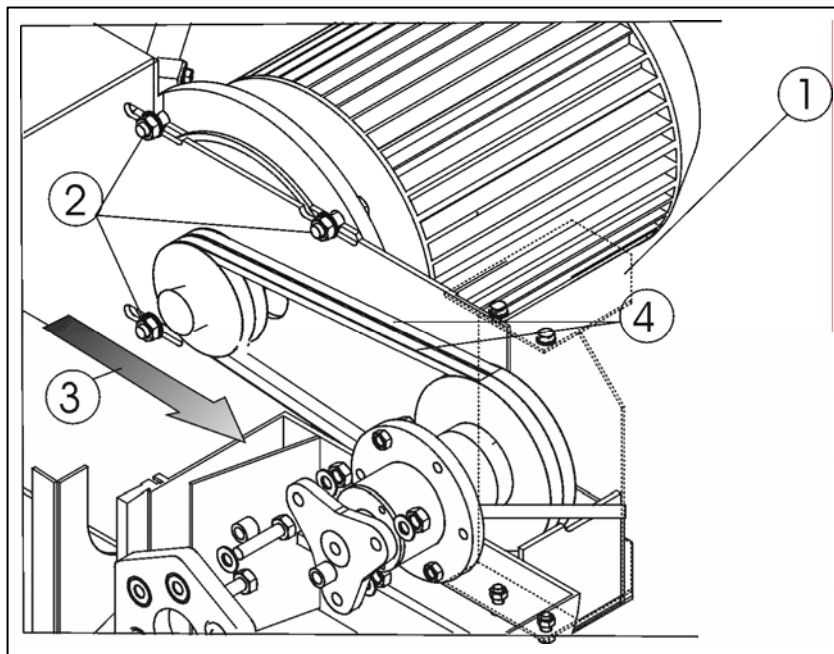

Fig. 7.4 (electric unit shown)



**Disassembly (refer to figure 7.4 on previous page):**

- 1 Unscrew the cover.
- 2 Unscrew the motor fastening screws.
- 3 Move the motor toward the bearing-unit using tensioning screw attached to the motor base.
- 4 Remove the V-Belt.

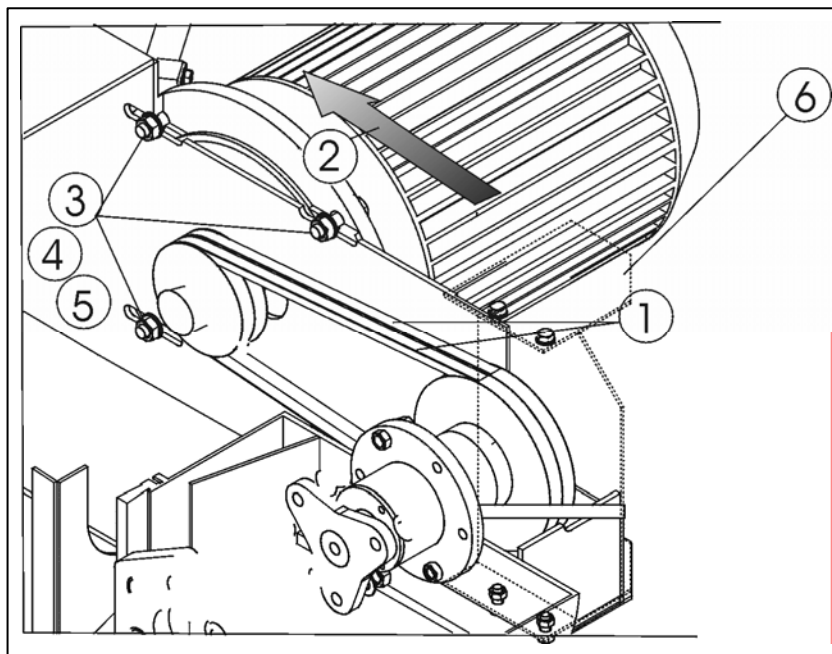

Fig. 7.5

**Assembly:**

- 1 Put on a new V-Belt.
- 2 Move the motor up to the operator panel using tensioning screw attached to the motor base.
- 3 Hand tighten the motor fastening screws.
- 4 Stretch the belt tension with the tensioning screw attached to the motor base. (Note the max permissible tension according to Fig. 7.6).
- 5 Tighten the motor fastening screws
- 6 Screw on the cover.



**Belt tension:**

The correct V-belt tension is of utmost importance in order to obtain a perfect power transmission and to reach the usual working life of the V-belt. Too low or too high tension causes premature breakdown of the V-belt. Excessive belt tension results in damaged bearings at the motor or bearing-unit.

To properly tension the belts, press the belt with your thumb midway between the pulleys as indicated in figure 7.6. When properly tensioned the belt should deflect between 5/16"-1/2" (8-13 mm).

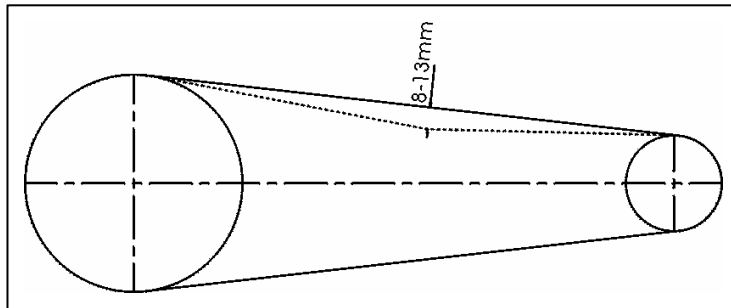

Fig. 7.6

---

**7.8 The driving motor**

---

The motor is designed for a long working life.

In case of malfunction of the motor, please contact Blastrac.



If the malfunction can not be repaired, please inform the **Blastrac** service center.

---

### 7.9 Additional maintenance

---

Check the brush seals for wear and replace when they do not provide sufficient sealing to the work surface. This will prevent dust from escaping and collecting on internal components.

Apply oil on the adjusting pin of the kick stand operating lever and other moving parts at regular intervals.

---

### 7.10 Spare

---

Blastrac recommends having the following spare parts on stock to avoid long down times.

Part No.	Description	Qty.
000118	Flexible coupling	2
P004077	Count S. Head Screw	20
B20507	Spacer tube	6
CG-1020DB	Diamond disc	1
B21014	Complete brush seal	1

---

### 7.11 Influences on the grinding pattern

---

The grinding pattern depends on the surface being treated.

Depending on the required surface profile you will have to vary the tools (Grinding disc). In order to get the best result compare the individual results of the tools.

Always check the grinding pattern after new or other types of tools have been fitted.

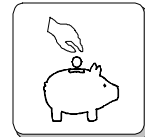



**Notes**



---

**Contents Chapter 8**

---

8.1 Directions for electrical engineering

8.2 Electric circuits diagrams

---

## 8.1 Directions for electrical engineering

---



Work on electrical equipment or operating materials may only be undertaken by a **skilled electrician** or by trained persons under the guidance and supervision of a skilled electrician as well as in accordance with the electrical engineering regulations.

Order the electric items with reference to the circuit diagrams in Section 8.2 or call a Blastrac service center.



**Operating Instructions**  
**Electrical**

---

**BG-250-230/60**  
**December 2006**

---

---

## **8.2 Wiring Schematic**

---

# BG-E 250 CONTROL PANEL FOR 230V/60Hz 1 PHASE

TOTAL FLA	LARGEST MOTOR FLA @ SUPPLY VOLTAGE
23.0 AMPS	23.0 AMPS 230V
PHASE - 1	ENCLOSURE - TYPE 1
HERTZ - 60	MODEL - BG-E 250/1
MAX. BRANCH CIRCUIT PROTECTION	30 AMPS

230V, SINGLE PHASE, 60 HZ  
30 AMP W/ GROUND

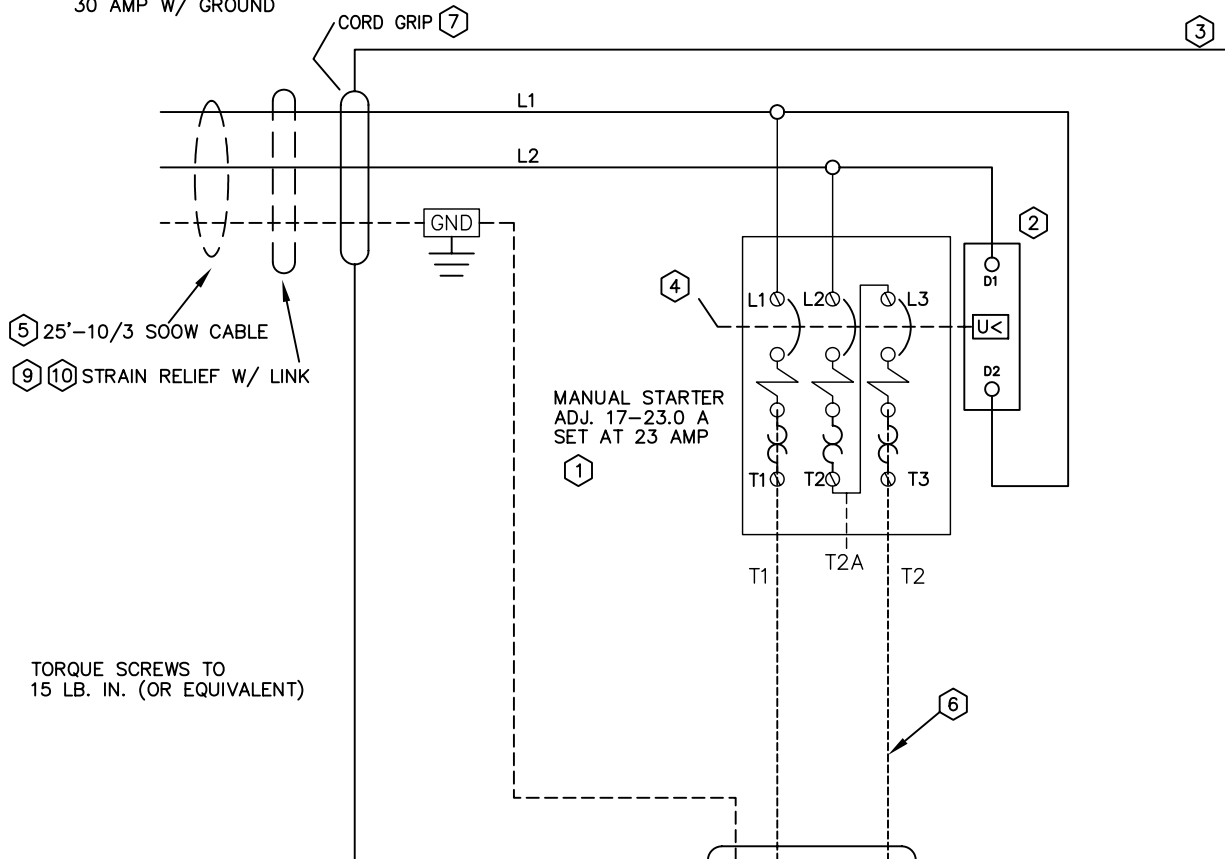

TORQUE SCREWS TO  
15 LB. IN. (OR EQUIVALENT)

**GENERAL NOTES:**

- A. BRANCH CIRCUIT PROTECTION MUST BE PROVIDED BY INSTALLER PER NEC 430-53(c)
- B. INSTALL ONLY COPPER FIELD CONDUCTORS RATED AT 75°C.
- C. THIS MACHINE MUST BE EFFECTIVELY GROUND FOR OPERATOR SAFETY. SEE NATIONAL ELECTRIC CODE ARTICLE 250.

**SCHEMATIC SYMBOLS**

[XX]	= TERMINAL BLOCK
(XX)	= VOLTAGE SELECTOR SWITCH TERMINAL
○	= ELECTRICAL JUNCTION
⊙XX	= COMPONENT TERMINAL AND NUMBER
XX	= WIRE NUMBER
(XX)	= WIRE COLOR AND AWG
<<(xx)	= PLUG/RECP TERMINAL NUMBER
PTT	= PUSH TO TEST PILOT LIGHT
---	= WIRE EXTERNAL TO ENCLOSURE

REV	DESCRIPTION	DATE	BY
<b>REVISION</b>			

THIS DRAWING AND THE DESIGN SHOWN THEREIN IS THE PROPERTY OF BLASTRAC AND USE OR COPIES THEREOF CANNOT BE MADE WITHOUT WRITTEN CONSENT.



6215 AVIATA VALLEY DRIVE  
OKTUBOGA CITY, OK 78121  
U.S.A.

DATE	6-3-05	DWG.	851-0028	NO.	P003761	SCALE	NTS	DRWN	ML
BG-E 250 230 VOLT 1 PHASE 60 Hz.						SHEET	1		851-0028
SCHEMATIC						OF	2		



**Operating Instructions**

**BG-250-230/60**

**Electrical**

**December 2006**

ITEM NUMBER	QTY	P/N	DESCRIPTION
1	1	P003744	MANUAL STARTER, 17-23 AMPS
2	1	P003745	UNDERVOLTAGE TRIP, 230 VAC 60 Hz (WAS GVAU226 - DETERMINATION TO USE LOWER VOLTAGE TRIP WAS MADE 11/29/2006 TO AVOID TRIPS CAUSED BY LOW VOLTAGE)
3	1	P003741	SURFACE MOUNT ENCLOSURE
4	1	P003740	MUSHROOM HEAD STOP BUTTON, TWIST RELEASE
5	50	P002254	10/3 TYPE SOOW CORD - 50' SECTION
6	5	P003748	10/3 TYPE SOOW CORD - 5' SECTION
7	2	P003739	CORD GRIP M25, .70 MAX DIA W/ LOCK NUT
8	1	P003097	CORD GRIP 3/4" W/LOCK NUT
9	1	714657	STRAIN RELIEF, DOUBLE EYELET, .75 CORD DIA
10	1	P000329	LINK, QUICK, 5/16, CLIP CLOSURE





**Operating Instructions**

**BG-250-230/60**

**Troubleshooting**

**October 2005**

---

---

**Contents Chapter 9**

---

9.1 Grinder troubleshooting

9.2 Electrical troubleshooting

**9.1 Grinder troubleshooting**



**Prior to any repair work on the machine or its drives the machine must be secured against unintentional starting. Put the machine in “Maintenance Mode.” See Chapter 2.6**

<b>Fault</b>	<b>Possible cause</b>	<b>Remedy</b>
Excessive vibration	Imbalance due to worn or broken grinding tools.	Replace all worn or broken parts. Check flexible coupling.
	Loose screws at the grinding disc	Tighten screws in the grinding disc.
Unusual noises	Defective axle bearing	Check axle bearing and replace if necessary.
	Wrong tension of the V-belt	Check the tension of the V-belt, replace the V-belt if necessary
	Dirt and debris in flexible coupling	Clean the coupling
Reduced or no grinding performance	Grinding tools have reached the maximum permissible wear	Replace the worn blades
	Inappropriate grinding tool for the application	Replace the grinding tools with appropriate grinding tools for the surface to be treated
	V-belt tension low	Tension the V-belt

## 9.2 Electrical/Motor troubleshooting

Work on electrical equipment may only be undertaken by a **skilled electrician** or by trained persons under the guidance and supervision of a skilled electrician as well as in accordance with the electrical engineering regulations.



**Prior to any repair work on the machine or its drives the machine must be secured against unintentional starting. Put the machine in “Maintenance Mode.” See Chapter 2.6**



Fault	Possible cause	Remedy
Motor does not start	E-Stop depressed	Pull out E-Stop
	Cables not correctly connected to site power.	Verify proper connection to site power.
	Site power not turned on.	Verify site power is turned on.

---

**Contents Chapter 10**

---

10.1 Spares Parts List BG-250-230/60

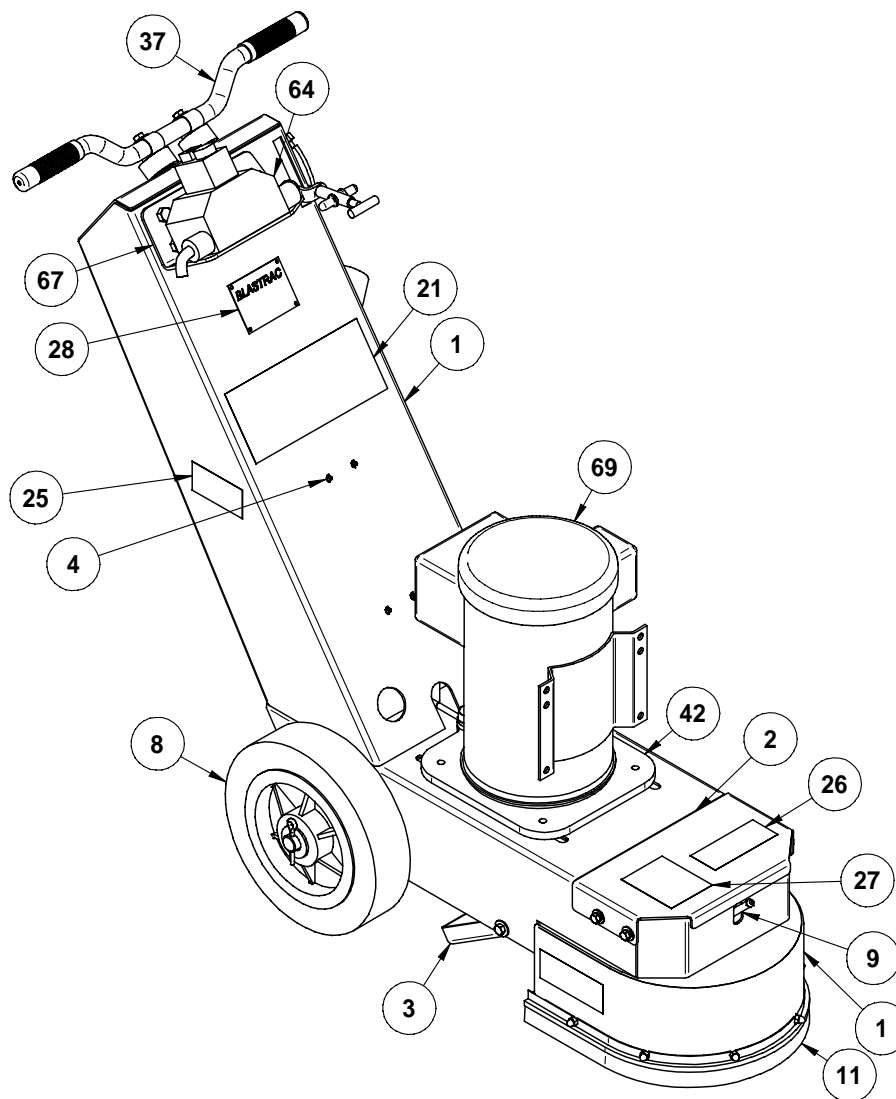

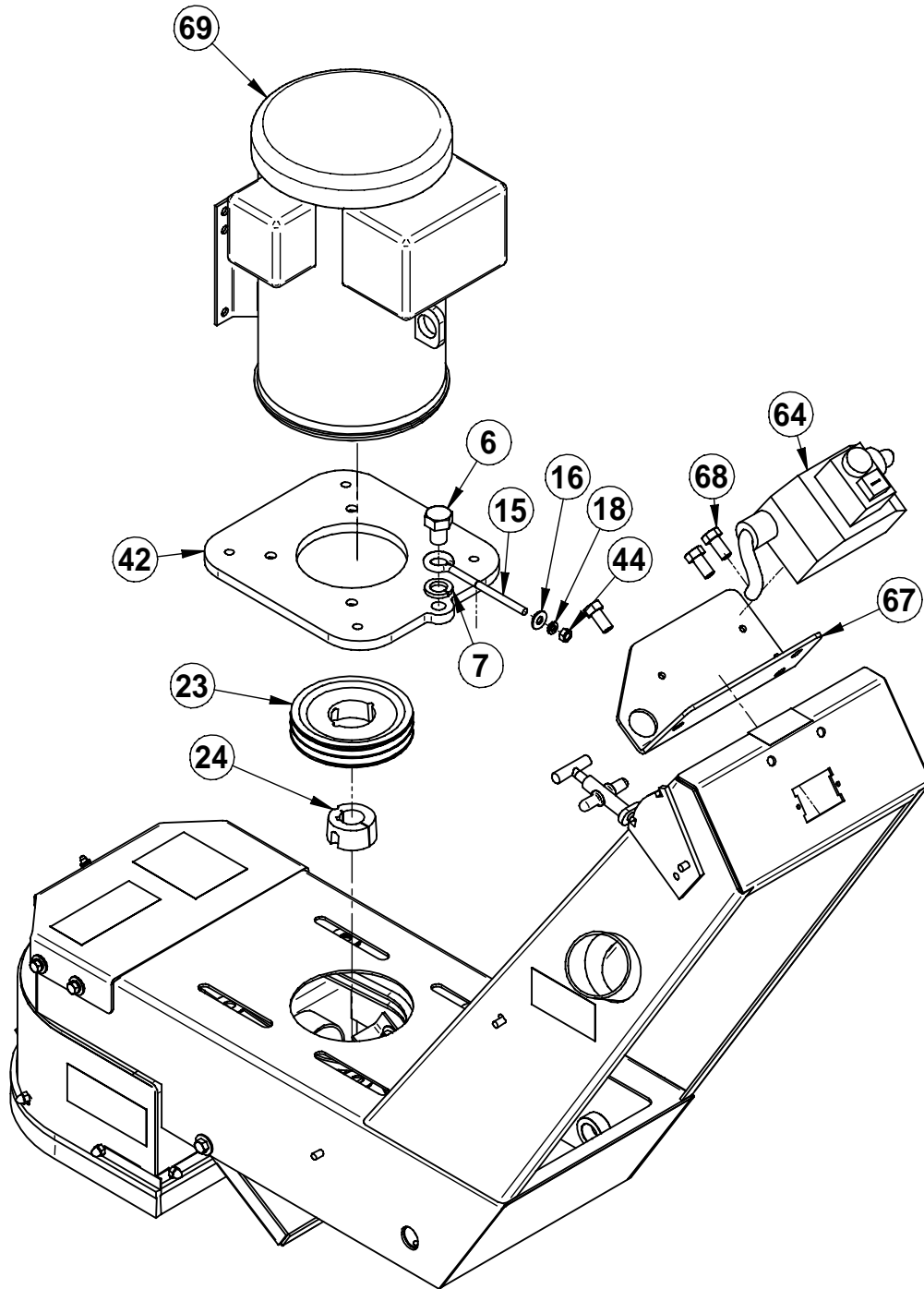

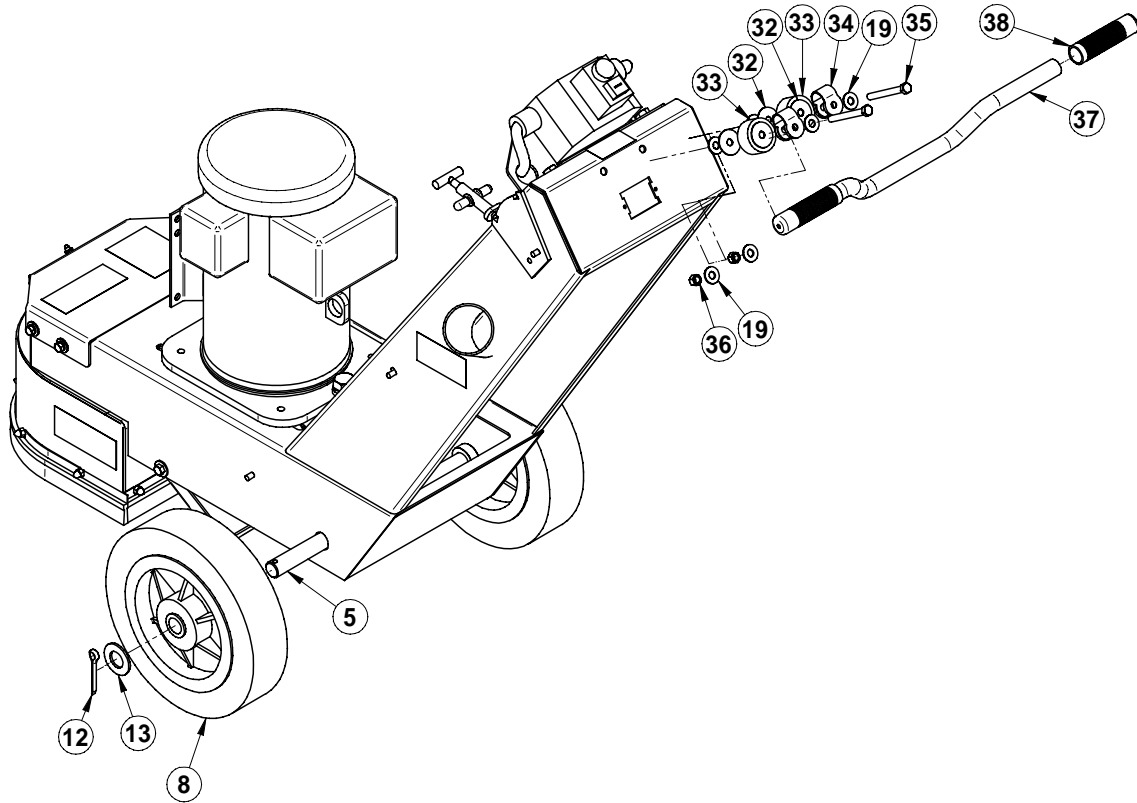

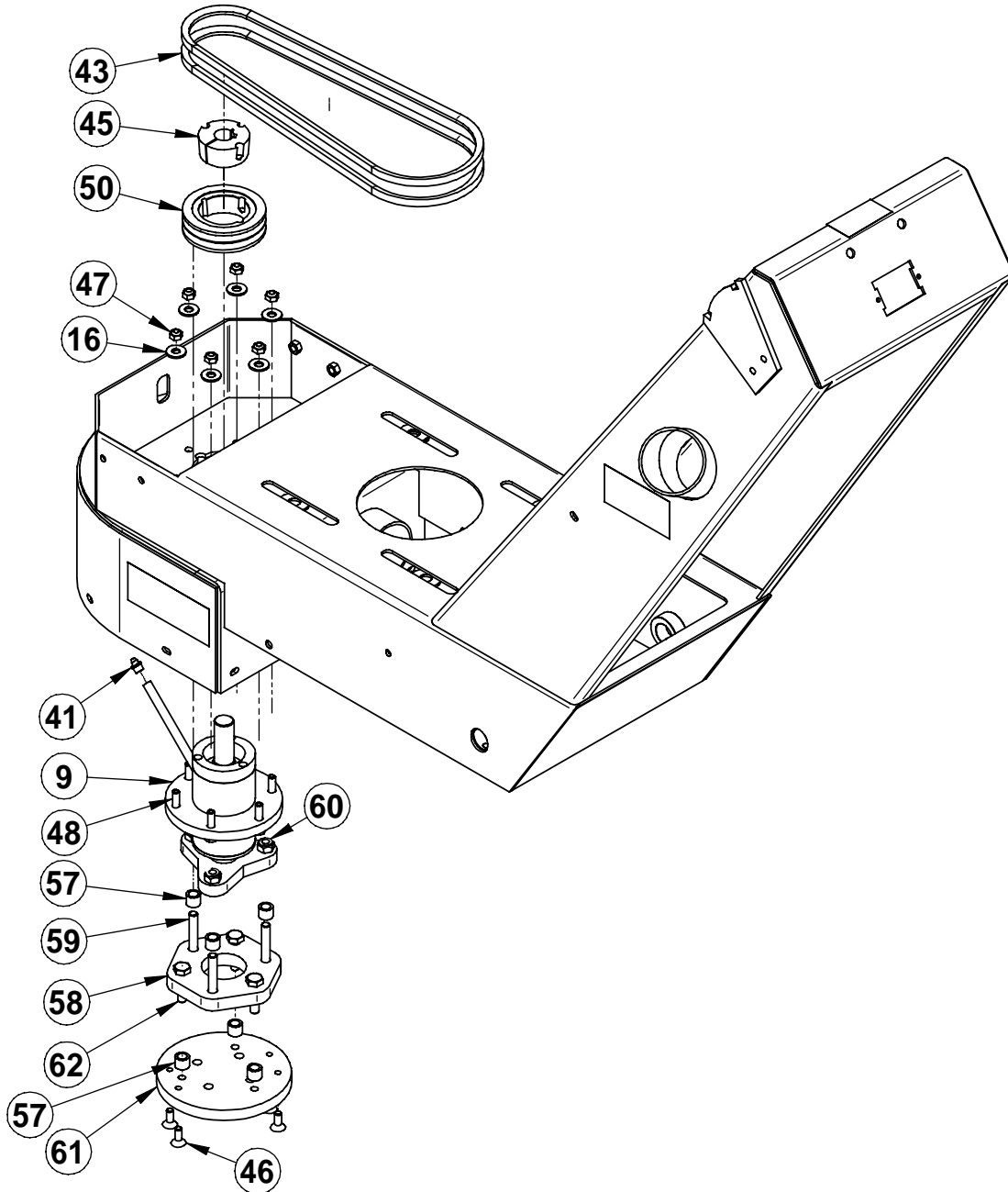

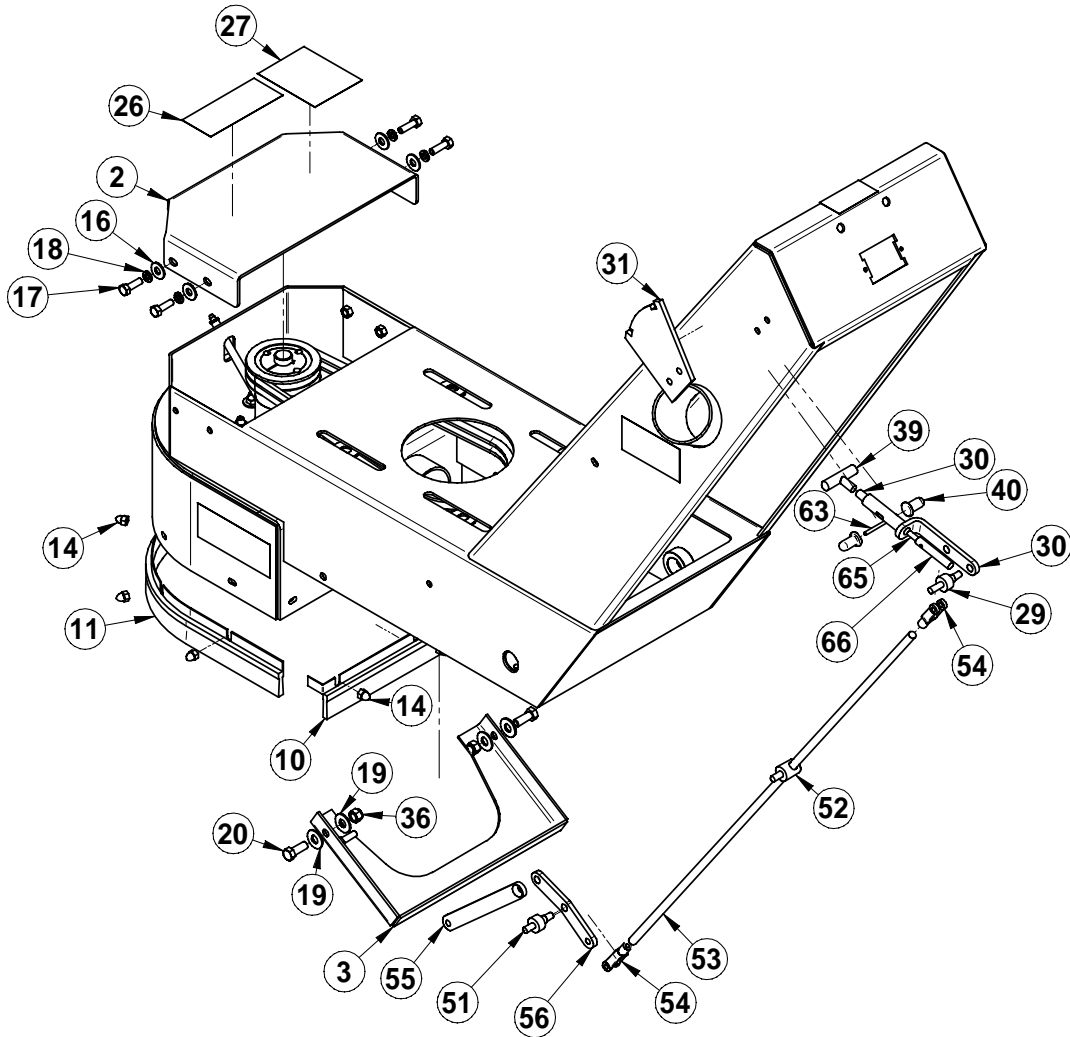





**Operating Instructions**

**BG-250-230/60**

**Spare Parts**

**October 2005**

10.1 Spares Parts List BG-250-230/60

ITEM	QUANTITY	CATALOG NUMBER	DRAWING NUMBER	DESCRIPTION
1	1	P003985	851-0009	CHASSIS WELDMENT
2	1	P003993	851-0017	GUARD / BELT
3	1	P003995	851-0019	KICK-STAND WELDMENT
4	4	5009720	--	SCREW/1/4"-20 BUTTON HEAD X 1.000"
5	1	P003994	851-0018	WHEEL AXLE
6	1	500267	--	SCR/CAP HEX 0.750-10 X 1.000
7	1	500118	--	WASHER/LOCK - 3/4"
8	2	P004009	--	CASTER / REAR
9	1	DG10	DG10	BEARING UNIT
10	1	DG28-1	DG28-1	BRUSH SEAL REAR
11	1	DG28-2	DG28-2	BRUSH SEAL CIRCULAR
12	2	5006040	--	PIN/COTTER 0.250 X 2.000
13	2	500110	--	WASHER/FLAT 1.00"
14	9	4822380	--	NUT / ACORN 0.250-20NC LOW CROWN
15	1	P003652	--	EYEBOLT / 5/16" X 6"
16	11	500103	--	WASHER, FLAT 5/16" DIA.
17	4	500190	--	SCR/CAP HEX 0.312-18 X 1.000
18	5	500114	--	WASHER/LOCK 5/16"
19	11	5001040	--	WASHER/FLAT 3/8"
20	2	5007670	--	SCR/CAP HEX 0.375-16 X 1.000
21	1	P000008	--	DECAL / BLASTRAC 4-3/8" X 10-1/2" WHITE/CLEAR
22*	1	05-65643	--	DECAL/WARNING-EYE AND EAR PROTECTION
23	1	P004015	--	SHEAVE 2GR3V 5.6-1610 TAPERLOCK (DODGE P/N 112195)
24	1	6300025	--	BUSHING/1610 x 1.125" DIA. T/L
25	2	P001419	--	DECAL/CAUTION EYE AND EAR PROTECTION REQUIRED
26	3	P002445	--	DECAL / WARNING-HOT SURFACE INSIDE
27	1	6854010	92B0193	DECAL / GUARD REMOVAL
28	1	P000818	--	PLATE/SERIAL NUMBER - BLASTRAC
29	1	DG57		PIVOT PIN/ADJUST HANDLE
30	1	DG55		HAND LEVER
31	1	DG51		ADJUST PLATE
32	4	6766290		WASHER/FENDER 13/32" ID
33	2	P004006	851-0021	ISOLATOR/HANDLE BAR
34	2	DG32		CLAMP/HANDLE BAR
35	2	5002030	--	SCREW/CAP HEX. 3/8"-16UNC X 3.25"
36	5	05-73723	--	3/8"-16 NYLOK NUT
37	1	DG31		HANDLE BAR



**Operating Instructions**

**BG-250-230/60**

**Spare Parts**

**October 2005**

38	2	DG44	--	HANDLE GRIP
39	1	DG63		ADJUSTMENT LEVER HANDLE
40	2	DG64		FINGER HANDLE
41	1	2230004	--	FITTING / GREASE-ZERT 1/8"NPT X STRT
42	1	P004050	851-0029	MOUNT/ELECTRIC MOTOR
43	2	6100021	--	BELT/ 3VX375
44	1	5000590	--	NUT/HEX 5/16"-18UNC
45	1	P004016	--	1610 X 22mm TAPERLOCK BUSHING (DODGE P/N 119236)
46	4	P003860	--	SCREW/FLAT HEAD SOCKET CAP M8 X 20 LG BLACK
47	6	05-96507		5/16" NYLOK NUT
48	6	5001910	--	SCR/CAP HEX 0.312-18 X 1.250
49*	6	5001060	--	WASHER/FLAT-1/2"
50	1	P003656	--	SHEAVE / 2GR3V 3.65-1610 TAPERLOCK
51	1	DG56		PIVOT PIN/LOWER
52	1	DG58		GUIDE BOLT/ADJUSTING ROD (PIN)
53	1	DG59		ADJUSTING ROD (PIN)
54	2	DG60	--	CLEVIS ROD END
55	1	DG52		LEVER
56	1	DG50		KNEE LEVER
57	6	B20507	B20507	TUBE / SPACER
58	1	118	--	FLEXIBLE COUPLING
59	3	P004002	--	SCR/CAP HEX M10.0 X 1.50 X 55 G8.8 STL
60	3	P004003	--	NUT/NYLON INSERTED M10.0 X 1.50
61	1	DG05	DG05	ADAPTER DISK
62	3	P004001	--	SCR/CAP HEX M10.0 X 1.50 X 40 G8.8 STL
63	1	DG53		BOLT
64	1	P003761	--	CONTROL PANEL AND HARNESS
65	1	DG66		SPRING
66	1	DG54		PLUNGER (BOLT)
67	1	P004055	851-0031	ELEC. ENCLOSURE BRACKET BG-250 230V 1PH
68	3	6956420	--	SCR/CAP HEX 0.500-13 X 1.000 G 8 STL
69	1	P004057		MOTOR/ELECTRIC 230V 1PH 5HP
70*	1	5001020	--	WASHER/FLAT 1/4"
71*	1	05-72000	--	NUT/HEX NYLOC 1/4"-20UNC
72*	1	P004054	851-0027	HOSE/DUST

